

System	Color	Off-axis Distance (mm)		
		0	10	20
200 mm f/10 Jones Focal Corrector  $R_F = 227$ mm	R			
	G			
	B			
○ Airy Disk				
200 mm f/10 Brixner Focal Corrector  $R_F = 400$ mm	R			
	G			
	B			
○ Airy Disk				
200 mm f/6 Jones-Bird Focal Corrector  $R_F = 72$ mm	R			
	G			
	B			
○ Airy Disk				

# Newton & focal corrector

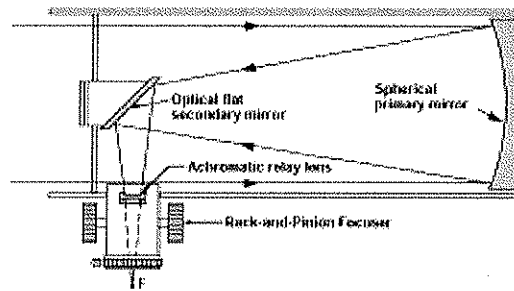

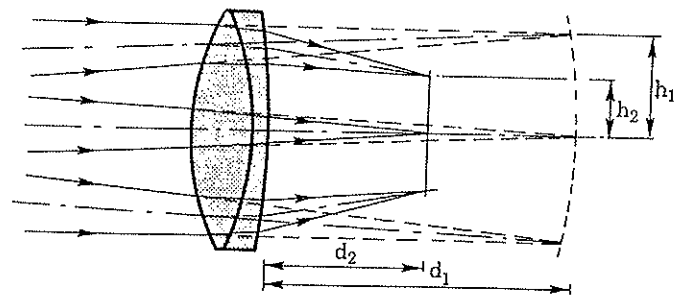

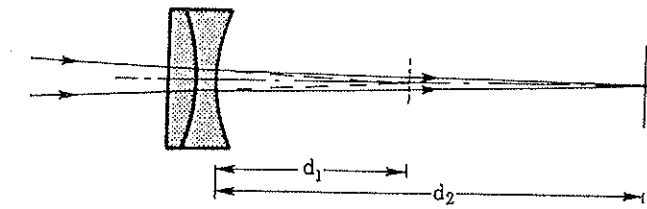

System	Color	Off-axis Distance (mm)	
		0	10
200 mm f/10 Schmidt-Cassegrain with Focal Reducer (focal ratio: f/5.5)	R		
$R_F = \infty$	B		
0.025 mm	V		

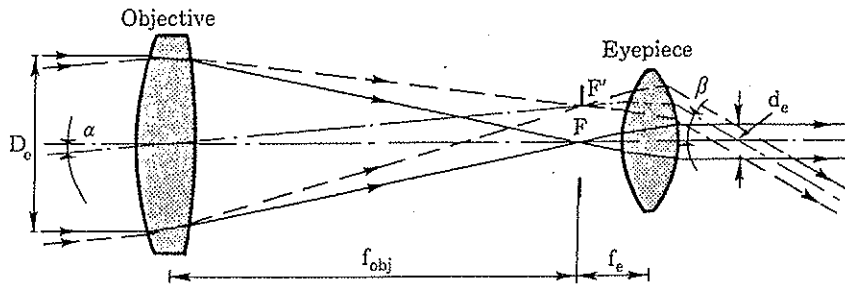
System	Color	Off-axis Distance (mm)			
		0	10	20	30
200 mm f/4 Schmidt-Cassegrain Flat-Field Camera	R				
$R_F = \infty$	B				
0.025 mm	V				

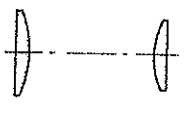
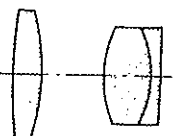
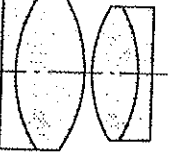
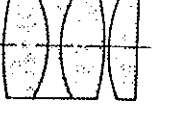
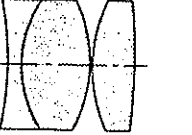

Scale: Focal Length	Name of Inventor	Apparent Field in Degrees	Year of Prototype	Remarks
	Huygens	50	1703	The first compound two lens eyepiece. With this type lateral color could be eliminated
	Ramsden	40	1783	
	Kellner	50	1849	
	Plössl	50	1860	Also called symmetrical
	Abbe	50	1880	Also called orthoscopic because of its low degree of distortion
	König	50	1915	
	Erfle	70	1917	The first genuine wide angle eyepiece developed for military applications

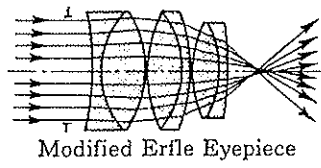
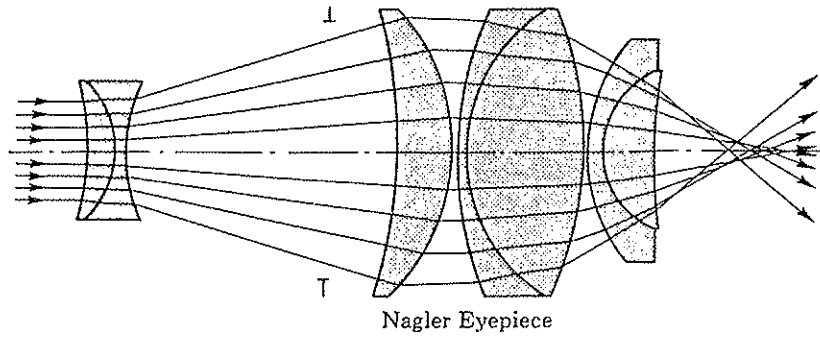

Focal Length

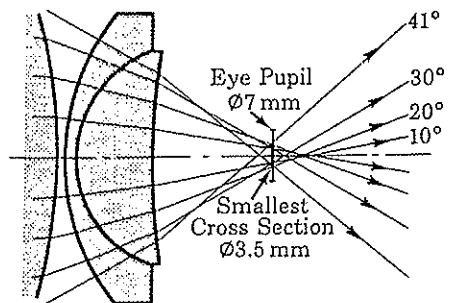
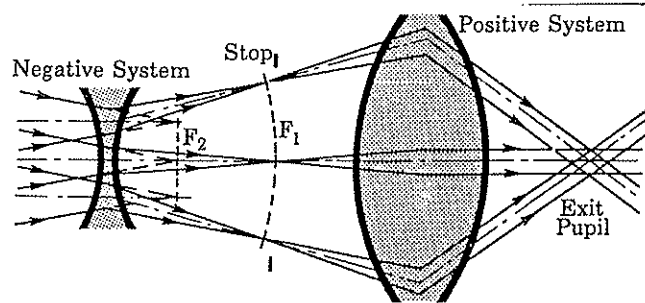

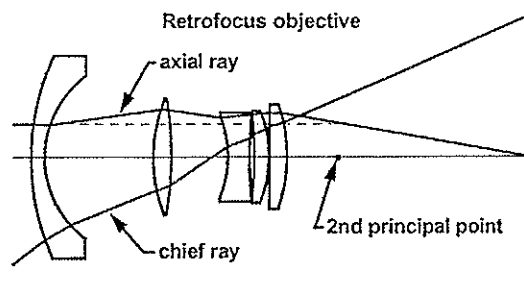
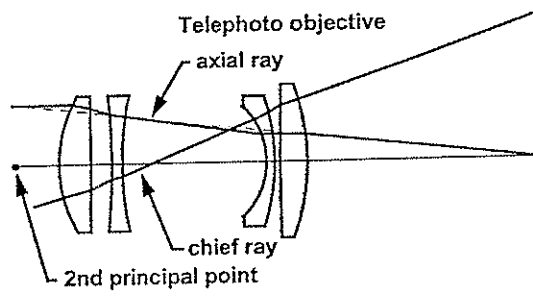
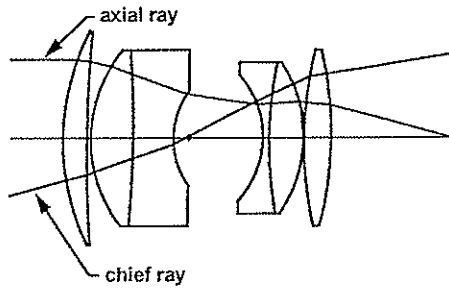

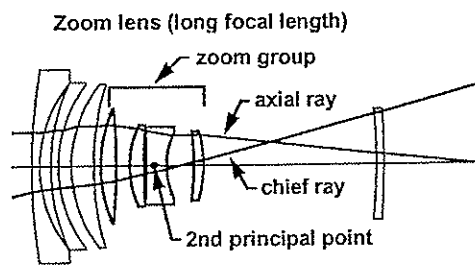
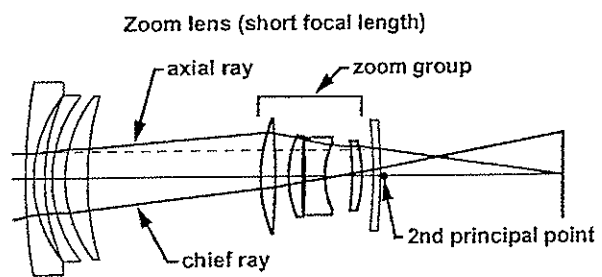

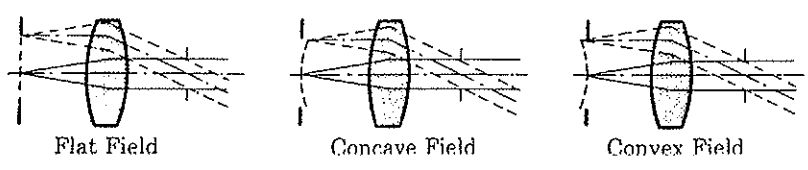
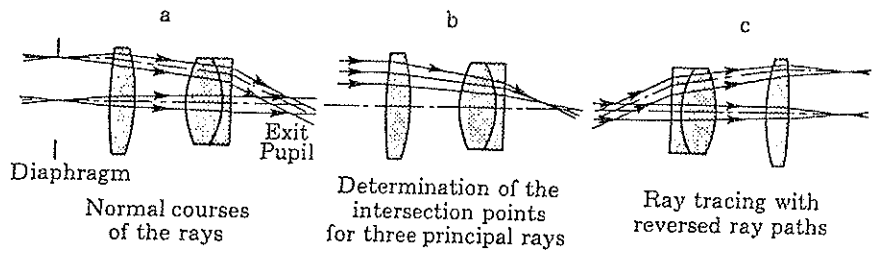
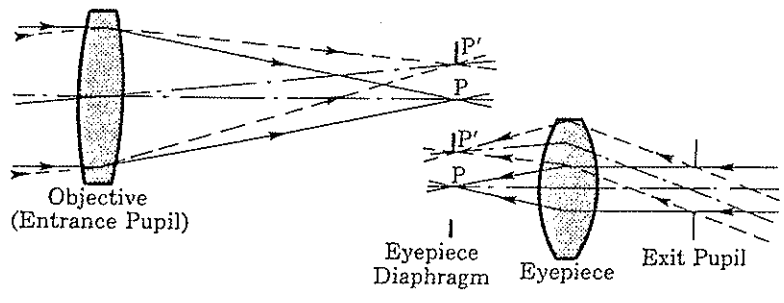

f/15 H-L field

Type of Eyepiece	Color	Off-axis Image Angle (degrees)		
		0	10	20
Huygenian	G			
Ramsden	G			
Kellner	G			
Plössl	G			
Abbe	G			
König	G			
Erfle	G			

5 Arcmin.   
1 Arcmin.

f/10 H-L

Type of Eyepiece	Color	Off-axis Image Angle (degrees)				
		0	10	20	25	30
Huygenian	G					
Ramsden	G					
Kellner	G					
Plössl	G					
Abbe	G					
König	G					
Erfle	G					

5 Arcmin.   
1 Arcmin.

f/15 H-L

Type of Eyepiece	Color	Off-axis Image Angle (degrees)				
		0	10	20	25	30
Huygenian	G					
Ramsden	G					
Kellner	G					
Plössl	G					
Abbe	G					
König	G					
Erfle	G					

5 Arcmin.   
1 Arcmin.

R, G, B: Relative positions of the principal rays for red, green, and blue light.

Curved field

Type of Eyepiece	Color	Off-axis Image Angle (degrees)			
		0	10	20	25
Huygenian	G				
f/5	G				
f/10	G				
f/15	G				
Ramsden	G				
f/5	G				
f/10	G				
f/15	G				

5 Arcmin.   
1 Arcmin.

Type of Eyepiece	Color	Off-axis Image Angle (degrees)				
		0	10	20	30	40
Six-Element Erfle  f/5	R					
	G					
	B					
Six-Element Erfle  f/10	R					
	G					
	B					
Six-Element Erfle  f/15 5 Arcmin. 1 Arcmin.	R					
	G					
	B					

Type of Eyepiece	Color	Off-axis Image Angle (degrees)				
		0	10	20	30	40
Nagler  f/5	R					
	G					
	B					
Nagler  f/10	R					
	G					
	B					
Nagler  f/15 5 Arcmin. 1 Arcmin.	R					
	G					
	B					

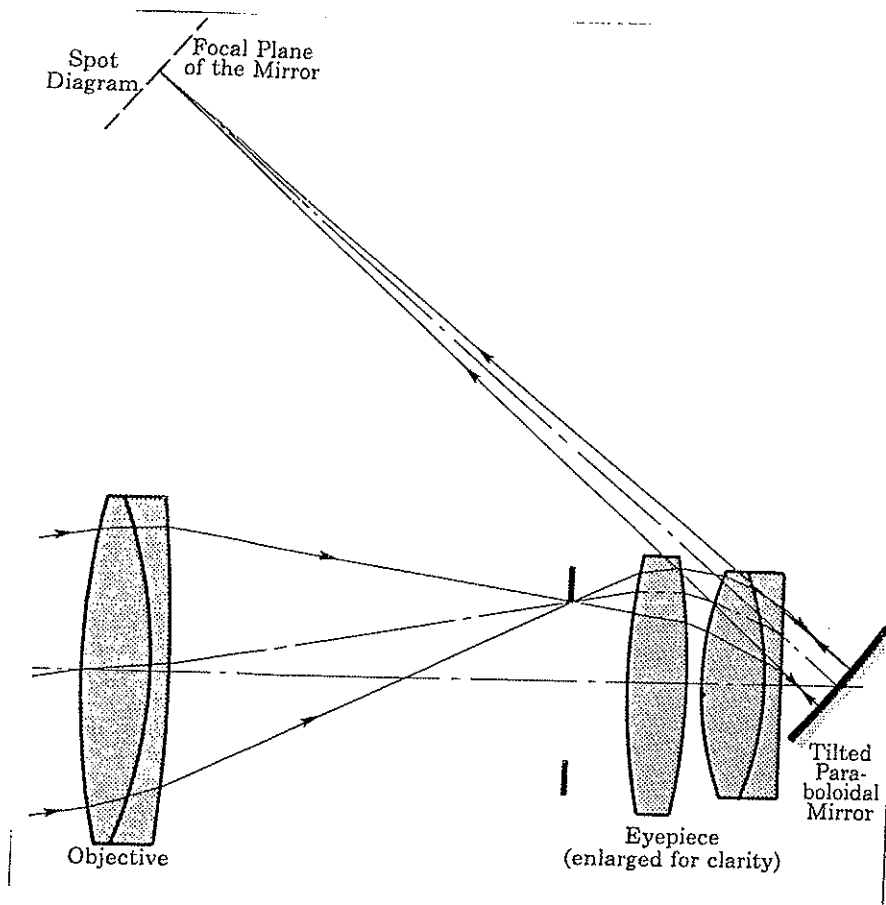

1 Arcmin. 5 Arcmin.	Off-axis Eyepiece Field Angle (degrees)					
	0	10	20	30	40	
200 mm f/6 Newtonian + Erfle 13	Objective					
	Eyepiece					60 Arcmin.
	Combination					63 Arcmin.
	Accommodation	0.3	0.2	0	0.5	2.6
200 mm f/6 Jones-Bird + Erfle 13	Objective					
	Eyepiece					60 Arcmin.
	Combination					47 Arcmin.
	Accommodation	1.7	1.6	0.6	0	0.5

1 Arcmin. 5 Arcmin.	Off-axis Eyepiece Field Angle (degrees)					
	0	10	20	30	40	
100 mm f/8 Fluorite Refractor + Erfle 13	Objective					
	Eyepiece					46 Arcmin.
	Combination					46 Arcmin.
	Accommodation	0.33	0.33	0	0.1	2.4
100 mm f/5.5 Four Lens Refractor + Erfle 13	Objective					
	Eyepiece					66 Arcmin.
	Combination					67 Arcmin.
	Accommodation	0.28	0.15	0	0.3	2.3

1 Arcmin. 5 Arcmin.	Off-axis Eyepiece Field Angle (degrees)					
	0	10	20	30	40	
200 mm f/6 Newtonian + Nagler 13	Objective					
	Eyepiece					
	Combination					
	Accommodation	0	0.13	0.35	0.60	0.35
200 mm f/6 Jones-Bird + Nagler 13	Objective					
	Eyepiece					
	Combination					
	Accommodation	2.8	2.6	2.3	1.8	0
100 mm f/8 Fluorite Refractor + Nagler 13	Objective					
	Eyepiece					
	Combination					
	Accommodation	0.13	0	0.24	0.43	0
100 mm f/5.5 Four-Element Refractor + Nagler 13	Objective					
	Eyepiece					
	Combination					
	Accommodation	0	0.13	0.43	0.60	0.50



# Okuláry a další příslušenství

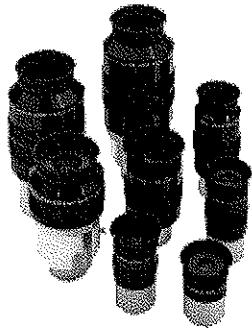

sada okulárů Plössl

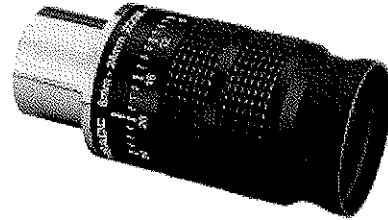

zoom 8–24mm

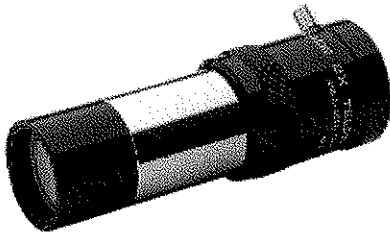

Barlow 2x

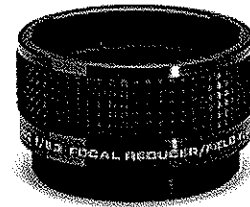

focal reducer  
field flattener

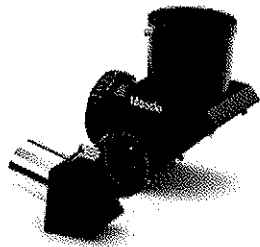

hranol

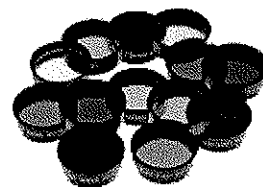

sada barevných filtrů

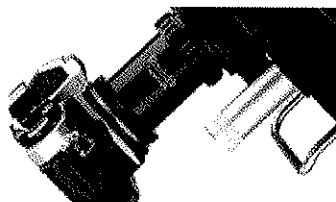

adaptér na 35mm kameru

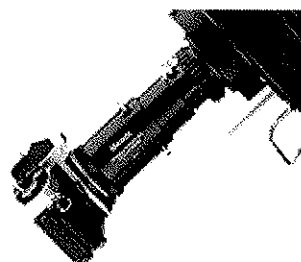

projekční nástavec

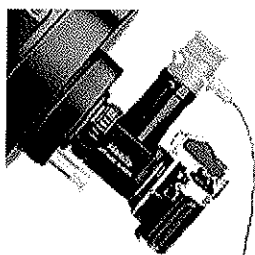

mimoosový pointační  
adaptér

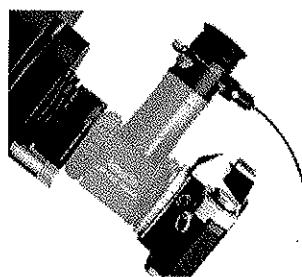

pointační okulár

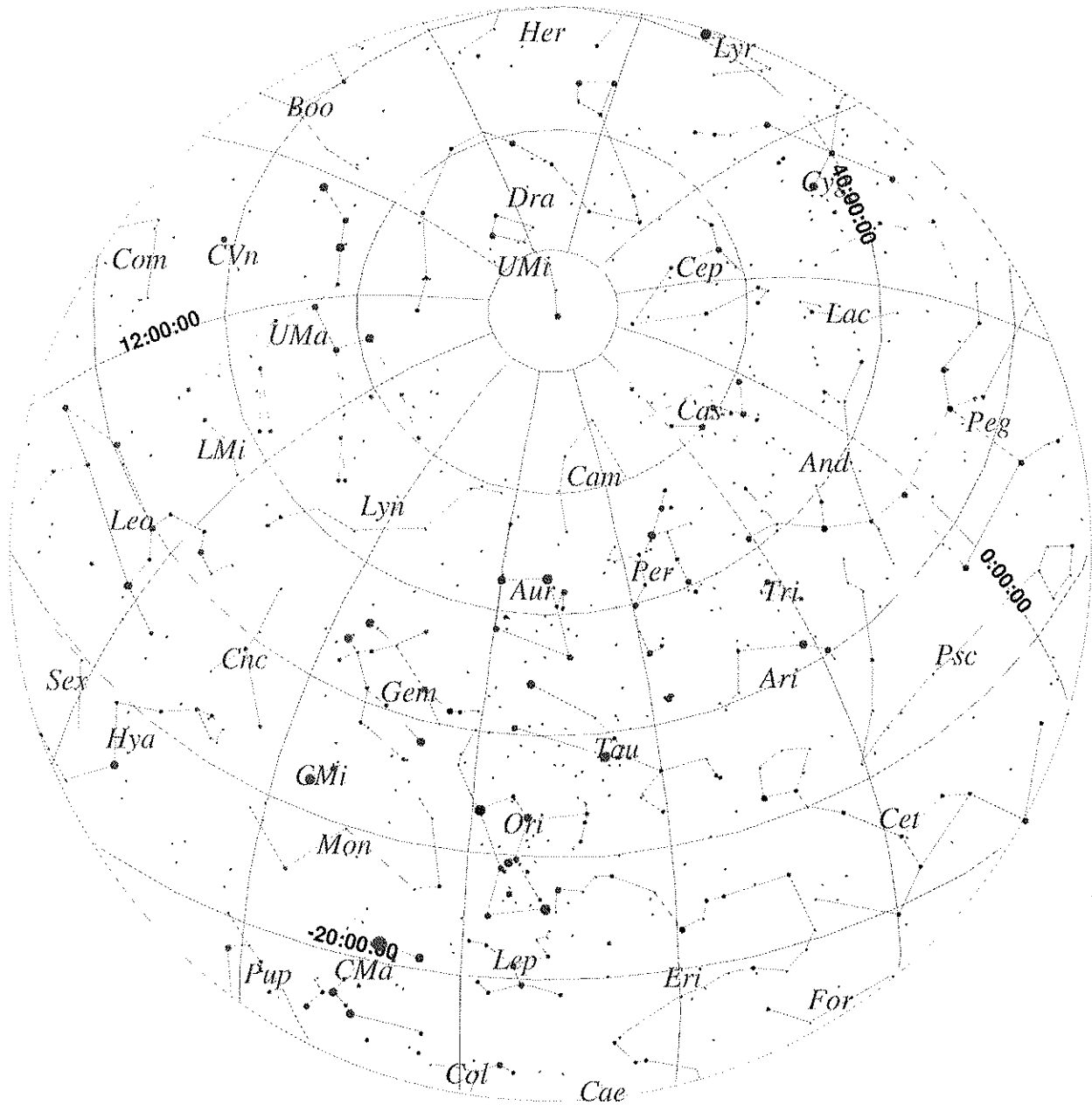

XEphem Topocentric Mean RA/Dec Sky View  
Prague, Czech Republic

RA: 5:12:00.0  
 Declination: 50:04:35  
 Epoch: 2000.00  
 Altitude: 90:00:00  
 Azimuth: 90:00:00  
 Field Width: 180:00

Grid Steps:  
 RA: 2:00:00  
 Dec: 20:00:00

Julian Date: 2452731.15020  
 Sidereal Time: 5:12:13  
 UTC Date: 4/01/2003  
 UTC Time: 15:36:17  
 Latitude: 50:05:00 N  
 Longitude: 14:24:00 E

Created by XEphem Version 3.5.2 8 Jan 2002  
 Copyright (c) 1990-2002 by Elwood Charles Downey  
<http://www.ClearSkyInstitute.com>  
 Generated Tue Apr 1 15:37:59 2003 UTC

# Montáže

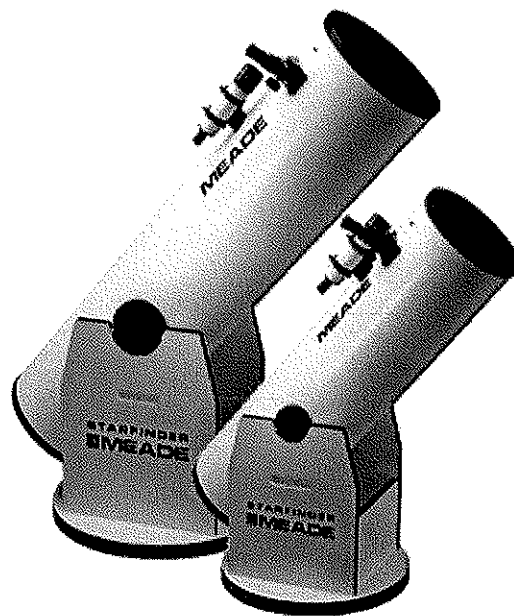
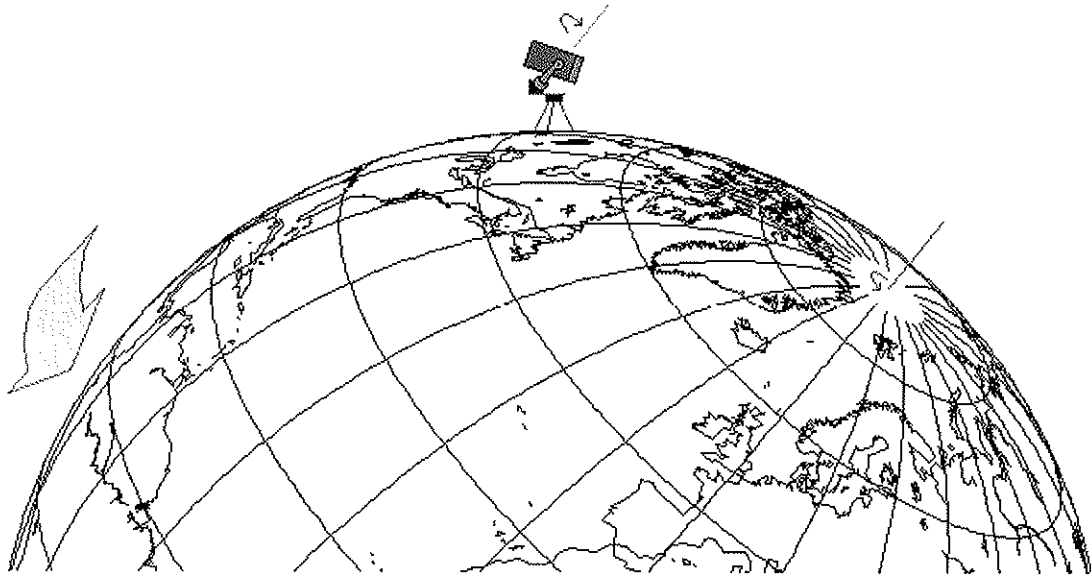

azimutální (Dobson)

# paralaktické montáže

německá



vidlicová

